

Part number

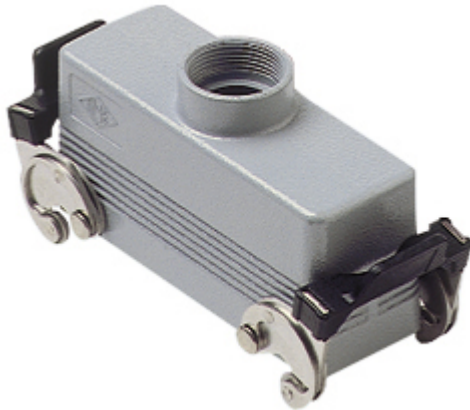

# CAV 24 X29



## Brief description:

hoods with two levers, size "104.27", top entry, Pg29, metal version, IP66 (EN 60529) and IP69K (DIN 40050 - 9) degree of protection.

Product description	
Version	metal version
Series	Hoods for 2 levers, without gasket
Product type	with 2 levers, without gasket
Variant	top entry
Style	high construction
Family	CLASS enclosures
Size	size "104.27"
Technical data	
Material	metal
IP degree of protection	IP66 (and IP69K DIN 40050 - 9)
Cable entry	Pg29
Further technical details	
Weight	350,00 g

Approvals / Standards	
Quality mark	 (type:4/4X/12),  , EAC
Conformity	CQC, CE
General ordering information	
EAN13 code	8015747010078
Tariff number	85369095
Packaging Information	
Packaging length	330,00 mm
Packaging height	170,00 mm
Packaging width	230,00 mm
Packaging weight	3,50 kg
Packaging volume	12,90 dm <sup>3</sup>
Packaging description	Carton box
Packaging quantity	10 Pcs
Packaging EAN code	8015747226219
Sub-packaging weight	1,75 kg
Sub-packaging description	Plastic pakaging
Sub-packaging quantity	5 Pcs
Sub-packaging EAN barcode	8015747010085

Part number

# CAV 24 X29



Catalogue drawings

**CHO X (CAO X) - MHO X (MAO X)**

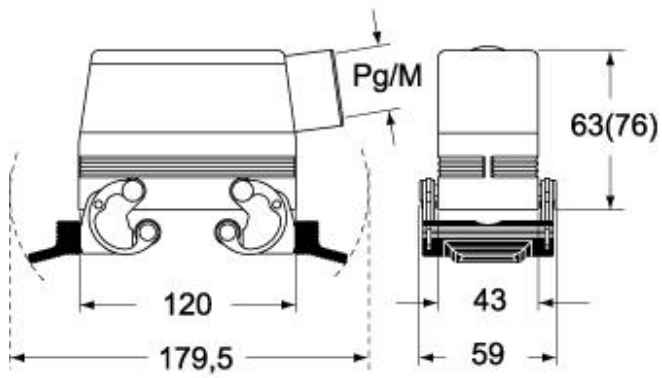

**CHV X (CAV X) - MHV X (MAV X)**

